

# CIT304TB

## 30-INCH INDUCTION COOKTOP

MASTERPIECE® SERIES BLACK FRAMELESS



Also Available:  
CIT304TM - Silver Mirrored Finish Frameless

### FEATURES & BENEFITS

- Powerful 3,700 W, 11" element for larger pots and pans
- Induction cooktops heat faster than traditional gas and electric cooktops
- PowerBoost® feature increases element power by up to 50%, saving time to heat up pots or cook large quantities
- Each element has its own shut-off timer, making it easier to coordinate the cooking of multiple dishes
- Illuminated touch controls with 17 power settings is highly precise and allows for easy cleaning

### ACCESSORIES (OPTIONAL)



CHEFSPAN08  
10" Stainless Steel Pan

### GENERAL PROPERTIES

Controls	Touch Controls
----------	----------------

### ELEMENT PERFORMANCE

Power of Front Left Heating Element	1,400 W
Power of Front Left Heating Element (In Boost)	2,200 W
Power of Back Left Heating Element	2,200 W
Power of Back Left Heating Element (In Boost)	3,700 W
Power of Center Heating Element	N/A
Power of Center Heating Element (In Boost)	N/A
Power of Front Right Heating Element	1,400 W
Power of Front Right Heating Element (In Boost)	2,200 W
Power of Back Right Heating Element	2,600 W
Power of Back Right Heating Element (In Boost)	3,700 W
Burners With Booster	All 4

### ELEMENT SIZE

Dimension of Front Left Heating Element	6"
Dimension of Back Left Heating Element	9"
Dimension of Center Heating Element	N/A
Dimension of Back Right Heating Element	11"
Dimension of Front Right Heating Element	6"

### TECHNICAL DETAILS

Watts (W)	7,200 W
Circuit Breaker (A)	40 A
Volts (V)	208 / 240 V
Frequency (Hz)	50 / 60 Hz
Plug Type	No Plug
Conduit	39" Flexible 3-Wire
Energy Source	Electric

### DIMENSIONS & WEIGHT

Overall Appliance Dimensions (HxWxD) (in)	3/8" + 3 7/8" x 31" x 21 1/4"
Required Cutout Size (HxWxD) (in)	3 7/8" x 28 3/4" x 19 7/8"
Minimum Distance From Counter Front (in)	2 1/2"
Minimum Distance From Rear Wall (in)	2 3/8"
Net Weight (lbs)	40 lbs

### WARRANTY

Limited Warranty, Entire Appliance, Parts and Labor	2 Year
---	--------

**CIT304TB**  
**30-INCH INDUCTION COOKTOP**  
 MASTERPIECE® SERIES BLACK FRAMELESS



**30-INCH COOKTOP AND CUTOUT DIMENSIONS**

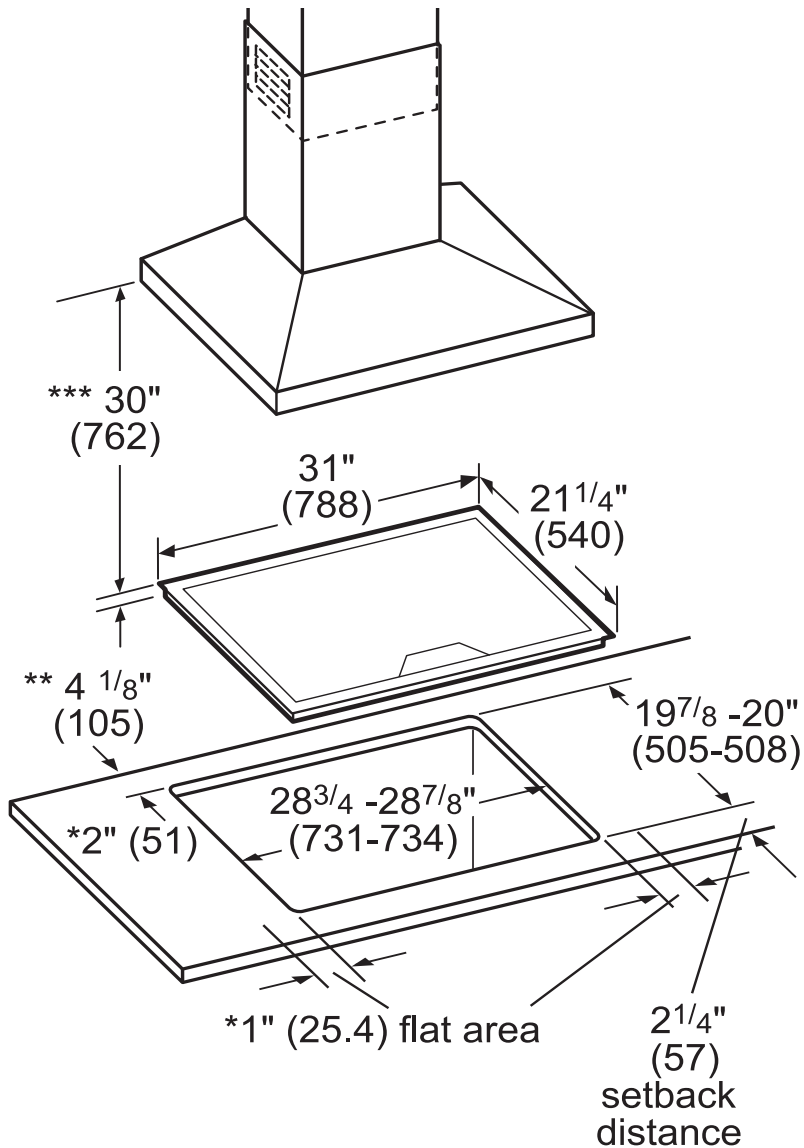

- \* Minimum distance from cutout to the wall
- \*\* Installed depth includes 1" (26 mm) needed air gap
- \*\*\* Minimum distance between the cooktop surface and lower edge of exhaust hood

measurements in inches (mm in brackets)

**NOTE:** The work surface should be horizontal and level. The stability of the countertop should be confirmed even after making the cutout.

**CIT304TB**  
**30-INCH INDUCTION COOKTOP**  
 MASTERPIECE® SERIES BLACK FRAMELESS



**INSTALLATION ABOVE A THERMADOR BUILT-IN OVEN**

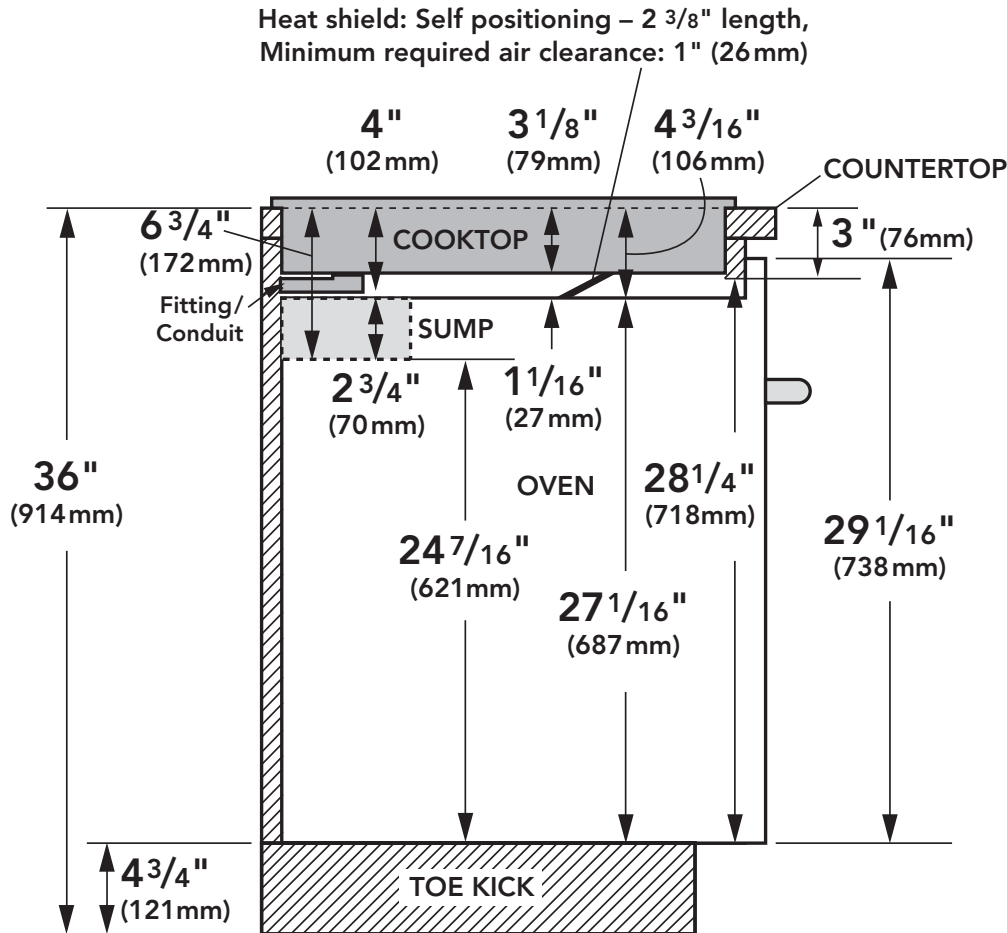

**Note:** Dimensions based on standard countertop height (36" with 4 3/4" toekick including base plate).

The built-in oven can be installed below the induction cooktop as long as there is an air clearance of 1" between the bottom of the cooktop and the top of the oven.

Sump applies to 30-inch Wall Ovens only.

These warranties give you specific legal rights and you may have other rights that vary from state to state. Full warranty and limited warranty from date of installation. For complete warranty details, refer to your Use & Care manual, or ask your dealer.

Specifications are for planning purposes only. Refer to installation instructions and consult your countertop supplier prior to making counter opening. Consult with a heating and ventilation engineer for your specific ventilation requirements. For the most detailed information, refer to installation instructions accompanying product or write to Thermador indicating the model number. Specifications are correct at time of printing. Thermador reserves the right to change product specifications or design without notice. Some models are certified for use in Canada. Thermador is not responsible for products that are transported from the U.S. for use in Canada.